

MEASURING PROCEDURE FOR RIGGING BOATS

Refer to: RIGGER SPEC. SHEET (One sheet per seat is required)

Required Tools: Tape-measure
Parallel Straight-edge
Protractor (If necessary a protractor can be borrowed from Rigtec Engineering.)

PROCEEDURE

- **Ref. Points 1 & 2** Measure the distance between the centres of the rigger bolts or the boat knees.
- **Ref. Points 3,4 & 5** Measure the width of the boat over the stern knee #3, the mainstay knee #4 and the bow knee #5 The measurement that we require doesn't include the "overhang or the top lip" of the gunwale flange. Ref. Figure 1.
- **Ref. Point 6** State the centre position of the oarlock axle / pin in relation to the centre line of the "Mainstay Knee." We require the distance towards the Bow or the Stern of the boat.
- **Ref. Points 7 & 8** Use the Straightedge and Protractor to measure the Stroke Side #7 and Bow Side #8 Gunwale angles. We require this to be carried out on the Mainstay Knee only. If the lip on the top of the gunwale interferes with the Protractor, use a parallel block to step the Protractor off the hull. Ref. Figure 2.
- **Ref. Point 9** Position the seat at the front-chocks and measure the distance between the straightedge and the lowest point on the stern edge of the seat top.
- **Ref. Points 10a,b,c** Measure the distance down from the top of the gunwale to the centre position of the top rigger bolt.
- **Ref. Points 11a,b,c** Measure the distance between the centres of the rigger bolts.
- **Ref. Point 12** If there is any variation that could interfere with the Rigger plates fitting onto the boat, measure the distance down from the centre of the bottom rigger bolt to the top edge of the where the interference would begin.

Notes:

The seats and riggers are numbered from the bow. Bow seat being No.1.

If there is a flange or a lip on the top of the gunwale, (as illustrated in figures 1 and 2) please provide us with a sketch showing measurements.

All riggers will be stamped with a serial number for our records.

Replacement riggers:

We will require the rigger "serial number" and the "seat number" to re-manufacture riggers from our records.

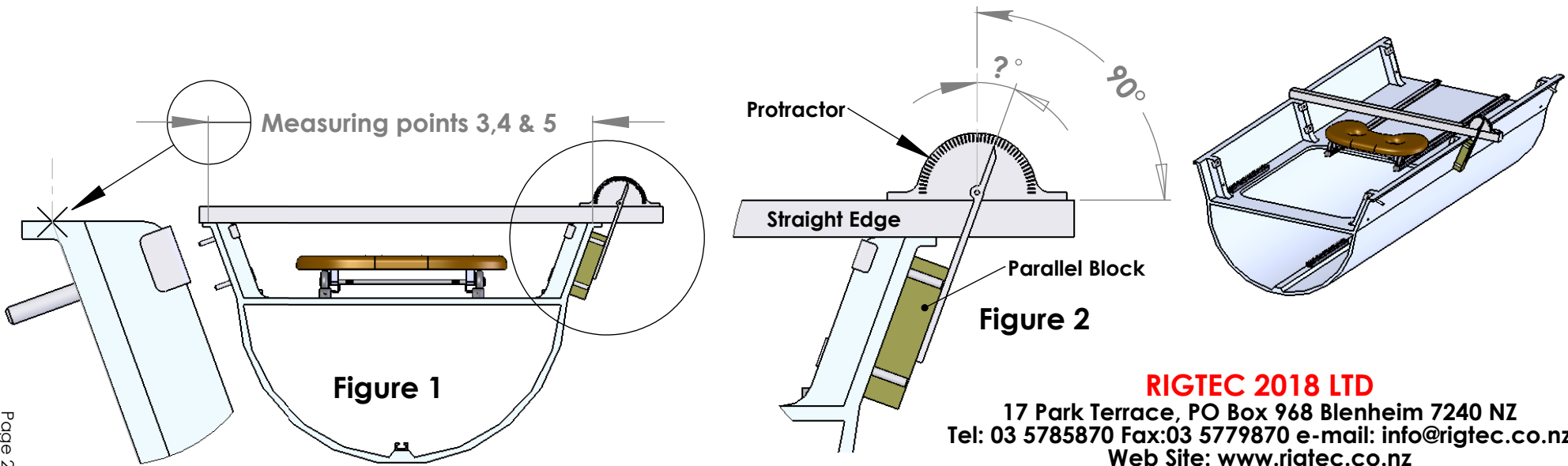

RIGTEC 2018 LTD

17 Park Terrace, PO Box 968 Blenheim 7240 NZ
Tel: 03 5785870 Fax:03 5779870 e-mail: info@rigtec.co.nz
Web Site: www.rigtec.co.nz